



Rental Grade Unit

MMG425 - 371kW John Deere

Generator-Mounted
Voltage Selector Switch

Sound Attenuated, Rust-Free
Aluminum Enclosure

Single-Point Lifting

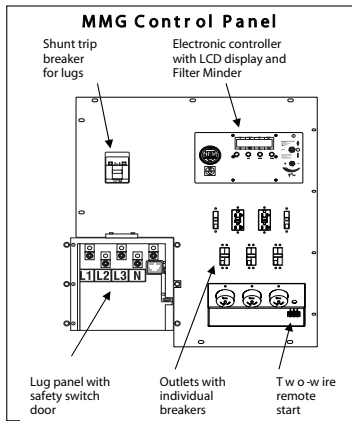

Easy Access to
Services Ports

Lockable
External Fuel Fill

24 Hour Fuel
Tank in Skid

TOUGH

- ALUMINUM ENCLOSURE
- LOCKABLE ENCLOSURE
- STEEL SKID AND TRAILER
- DURABLE POWDER COAT FINISH

RELIABLE

- SOPHISTICATED MICROPROCESSOR
- VOLTAGE REGULATION WITHIN 1%
- 24 HOUR FULL LOAD RUN TIME
- AIR FILTER CONDITION INDICATOR
- 1 YEAR 1,000 HOUR WARRANTY

EASY TO USE

- VOLTAGE SELECTOR
- LUGS AND LUG BOX SAFETY SWITCH
- MULTIPLE CONVENIENCE OUTLETS
- EXTERNAL EMERGENCY STOP SWITCH
- EXTERNAL, LOCKABLE FUEL CAP
- AUTOMATIC REMOTE START
- ENHANCED MOTOR
- STARTING OPTION AVAILABLE

Rental Grade Unit

MMG425 - 371kW John Deere

Output	
3 Phase - Standby (kW/kVa)	371 / 464
Amps (480/208 V)	558 / 1288
3 Phase - Prime (kW/kVa)	340 / 425
Amps (480/208 V)	511 / 1180
1 Phase - Standby (kW/kVa)	NA
Amps (240 V)	NA
1 Phase - Prime (kW/kVa)	NA
Amps	NA
AC Voltage - 1 Phase	NA
AC Voltage - 3 Phase	208 / 480
Frequency Hz.	60
Power Factor	.8 (3 Phase)
Generator (Brand/Type/Insulation)	Marathon / Brushless / H
Sound (dB(A) 23 Feet @ Prime)	68
Size & Weight	
Skid Mounted (L x Wx H)	175 x 60 x 96
Dry Weight lb. (kg.)	12105 (5491)
Operating Weight lb. (kg.)	17064 (7740)
Trailer Mounted (L x W x H) (in.)	250 x 102 x 116
Dry Weight lb. (kg.)	15355 (6965)
Operating Weight lb. (kg.)	20314 (9214)
Engine	
Brand	John Deere
Aspiration	Turbo
HP (Prime @ 1800 rpm) (kWm)	512 (382)
Displacement C.I.D. (l.)	763 (12.5)
Cylinders	6
Speed (rpm)	1800
Fuel Consumed (Prime gal. (l.)/h)	25.2 (95.2)
Battery (12 volt)	2 - 12V/1000 CCA
Capacities	
Fuel Tank gal.(l.)	630 (2385)
Approximate Run Time (hrs.)	24
Coolant qt. (l.)	94 (89)
Oil qt. (l.)	44 (42)
AC Distribution	
Main Breaker	1600
Voltage Selection	Link Board / Reconnect Board
Voltage Regulation	+/-1%
120V - 20 Amp GFI Duplex	2
240V - 30 Amp Twist Lock	NA
240V - 50 Amp Twist Lock	3
Trailer	
Number of Axles & Capacity (lbs.)	3 (8000)
Tire Size (in.)	17.5
Brakes	Electric
Hitch	3" Ring