



Rental Grade Unit MMG180 - 155kW John Deere

Generator-Mounted
Voltage Selector Switch

Sound Attenuated, Rust-Free
Aluminum Enclosure

Single-Point Lifting

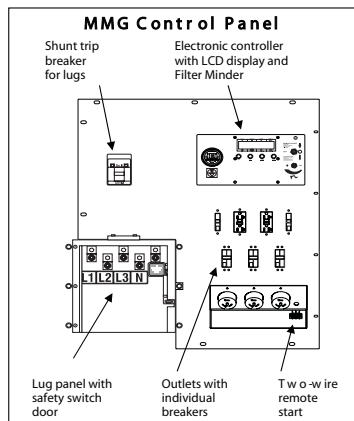

Easy Access to
Services Ports

Lockable
External Fuel Fill

24 Hour Fuel
Tank in Skid

TOUGH

- ALUMINUM ENCLOSURE
- LOCKABLE ENCLOSURE
- STEEL SKID AND TRAILER
- DURABLE POWDER COAT FINISH

RELIABLE

- SOPHISTICATED MICROPROCESSOR
- VOLTAGE REGULATION WITHIN 1%
- 24 HOUR FULL LOAD RUN TIME
- AIR FILTER CONDITION INDICATOR
- 1 YEAR 1,000 HOUR WARRANTY

EASY TO USE

- VOLTAGE SELECTOR SWITCH
- LUGS AND LUG BOX SAFETY SWITCH
- MULTIPLE CONVENIENCE OUTLETS
- EXTERNAL EMERGENCY STOP SWITCH
- EXTERNAL, LOCKABLE FUEL CAP
- AUTOMATIC REMOTE START
- ENHANCED MOTOR
- STARTING OPTION AVAILABLE

Rental Grade Unit

MMG180 - 155kW John Deere

Output	
3 Phase - Standby (kW/kVa)	155 / 194
Amps (480/208 V)	233 / 538
3 Phase - Prime (kW/kVa)	145 / 181
Amps (480/208 V)	218 / 503
1 Phase - Standby (kW/kVa)	125 / 125
Amps (240 V)	512
1 Phase - Prime (kW/kVa)	120 / 120
Amps	500
AC Voltage - 1 Phase	120, 139, 208, 220, 240, 277
AC Voltage - 3 Phase	208, 220, 440, 480
Frequency Hz.	60
Power Factor	1.0 (1 Phase) / .8 (3 Phase)
Generator (Brand/Type/Insulation)	Marathon / Brushless / H
Sound (dB(A) 23 Feet @ Prime)	68
Size & Weight	
Skid Mounted (L x Wx H)	132 x 50 x 77
Dry Weight lb. (kg.)	6300 (2860)
Operating Weight lb. (kg.)	8890 (4035)
Trailer Mounted (L x W x H) (in.)	210 x 86 x 93
Dry Weight lb. (kg.)	8240 (3740)
Operating Weight lb. (kg.)	10830 (4910)
Engine	
Brand	John Deere
Aspiration	Turbo
HP (Prime @ 1800 rpm) (kWm)	228 (170)
Displacement C.I.D. (l.)	415 (6.8)
Cylinders	6
Speed (rpm)	1800
Fuel Consumed (Prime gal. (l.)/h)	11.0 (41.6)
Battery (12 volt)	1 - 12V/1000 CCA
Capacities	
Fuel Tank gal.(l.)	360 (1363)
Approximate Run Time (hrs.)	32
Coolant qt. (l.)	42 (39.7)
Oil qt. (l.)	33 (31)
AC Distribution	
Main Breaker	700
Voltage Selection	3 Position Switch (Locable)
Voltage Regulation	+/-1%
120V - 20 Amp GFI Duplex	2
240V - 30 Amp Twist Lock	NA
240V - 50 Amp Twist Lock	3
Trailer	
Number of Axles & Capacity (lbs.)	2 (6000)
Tire Size (in.)	16
Brakes	Surge / Electric
Hitch	2" Ball / 3" Ring