



# Rental Grade Unit MMG35 - 29kW John Deere

Generator-Mounted  
Voltage Selector Switch

Sound Attenuated, Rust-Free  
Aluminum Enclosure

Single-Point Lifting

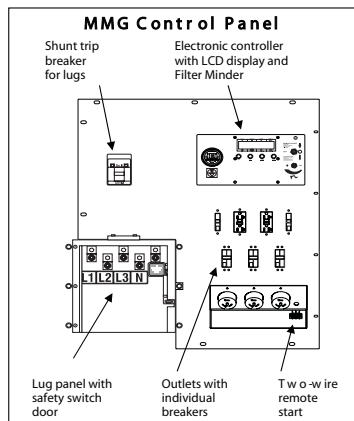

Easy Access to  
Services Ports

Lockable  
External Fuel Fill

24 Hour Fuel  
Tank in Skid



## TOUGH

- ALUMINUM ENCLOSURE
- LOCKABLE ENCLOSURE
- STEEL SKID AND TRAILER
- DURABLE POWDER COAT FINISH

## RELIABLE

- SOPHISTICATED MICROPROCESSOR
- VOLTAGE REGULATION WITHIN 1%
- 24 HOUR FULL LOAD RUN TIME
- AIR FILTER CONDITION INDICATOR
- 1 YEAR 1,000 HOUR WARRANTY

## EASY TO USE

- VOLTAGE SELECTOR SWITCH
- LUGS AND LUG BOX SAFETY SWITCH
- MULTIPLE CONVENIENCE OUTLETS
- EXTERNAL EMERGENCY STOP SWITCH
- EXTERNAL, LOCKABLE FUEL CAP
- AUTOMATIC REMOTE START
- ENHANCED MOTOR
- STARTING OPTION AVAILABLE

# Rental Grade Unit

## MMG35 - 29kW John Deere

<b>Output</b>	
3 Phase - Standby (kW/kVa)	29 / 36
Amps (480/208 V)	43 / 100
3 Phase - Prime (kW/kVa)	26 / 33
Amps (480/208 V)	40 / 92
1 Phase - Standby (kW/kVa)	26 / 26
Amps (240 V)	108
1 Phase - Prime (kW/kVa)	24 / 24
Amps	100
AC Voltage - 1 Phase	120, 139, 208, 220, 240, 277
AC Voltage - 3 Phase	208, 220, 440, 480
Frequency Hz.	60
Power Factor	1.0 (1 Phase) / .8 (3 Phase)
<b>Generator (Brand/Type/Insulation)</b>	Marathon / Brushless / H
<b>Sound (dB(A) 23 Feet @ Prime)</b>	68
<b>Size &amp; Weight</b>	
Skid Mounted (L x Wx H)	83 x 35 x 53
Dry Weight lb. (kg.)	2020 (920)
Operating Weight lb. (kg.)	2475 (1125)
Trailer Mounted (L x W x H) (in.)	132 x 57 x 68
Dry Weight lb. (kg.)	2540 (1150)
Operating Weight lb. (kg.)	2990 (1350)
<b>Engine</b>	
Brand	John Deere
Aspiration	Turbo
HP (Prime @ 1800 rpm) (kWm)	43 (32)
Displacement C.I.D. (l.)	149 (2.4)
Cylinders	4
Speed (rpm)	1800
Fuel Consumed (Prime gal. (l.)/h)	2.6 (9.8)
Battery (12 volt)	1 - 12V/1000 CCA
<b>Capacities</b>	
Fuel Tank gal.(l.)	62 (234)
Approximate Run Time (hrs.)	24
Coolant qt. (l.)	16.0 (15.1)
Oil qt. (l.)	8.5 (8.0)
<b>AC Distribution</b>	
Main Breaker	125
Voltage Selection	3 Position Switch (Locable)
Voltage Regulation	+/-1%
120V - 20 Amp GFI Duplex	2
240V - 30 Amp Twist Lock	NA
240V - 50 Amp Twist Lock	2
<b>Trailer</b>	
Number of Axles & Capacity (lbs.)	1 (3500)
Tire Size (in.)	15
Brakes	None / Surge / Electric
Hitch	2" Ball / 3" Ring